

Rotation Air Blower Machine.

Instructions Manual



Rotation Air Blower Machine

Serial No. 002-2023

Contact Maker

TECHNICIANSERVICE CO.,LTD

Tel. 02-1389755

Fax. 02-1389754

E-Mail : tech_cnc@technicianservice.co.th

[www. http://www.technicianservice.co.th](http://www.technicianservice.co.th)

SAFETY INSTRUCTIONS

**WARNING : FAILURE TO FOLLOW THESE RULES
MAY RESULT IN SERIOUS PERSONAL**

As with all machinery there are certain hazards involved with operation and use of the machine. Using the machine with respect and caution will considerably lessen the possibility of personal injury. However, if normal safety precautions are overlooked or ignored, personal injury to the operator may result.

This machine was designed for certain applications only. We strongly recommends that this machine. NOT be modified and/or used for any application other than for which it was designed. If you have any questions relative to its application DO NOT use the machine until you have had detail instruction from your dealer.

Table of Contents

Page

CONTACT US.....	2
SAFETY INSTRUCTIONS.....	2
SPECIFICATIONS.....	4
APPLIANCE DIMENSIONS.....	4
PARTS LIST	5
PARTS LIST SET AIR BLOW 1	6
PARTS LIST SET : AIR BLOWER 1 (SET BLOWER SLIDING).....	7
PARTS LIST SET : AIR BLOWER 1 (SET CYLINDER).....	9
PARTS LIST SET : AIR BLOWER 1 (SET CYLINDER).....	9
PARTS LIST SET : AIR BLOWER 1 (KEYPAD).....	22
PNEUMATIC CYCLE.	23
PROGRAMMABLE LOGIC CONTROLLER	24
PARTS LIST SET : AIR TANK 2.....	25

SPECIFICATIONS:

Air Blower Serial No.001-2021

Volage 220VAC 1Phase

Switching Power Supply 24VDC 5A

APPLIANCE DIMENSIONS

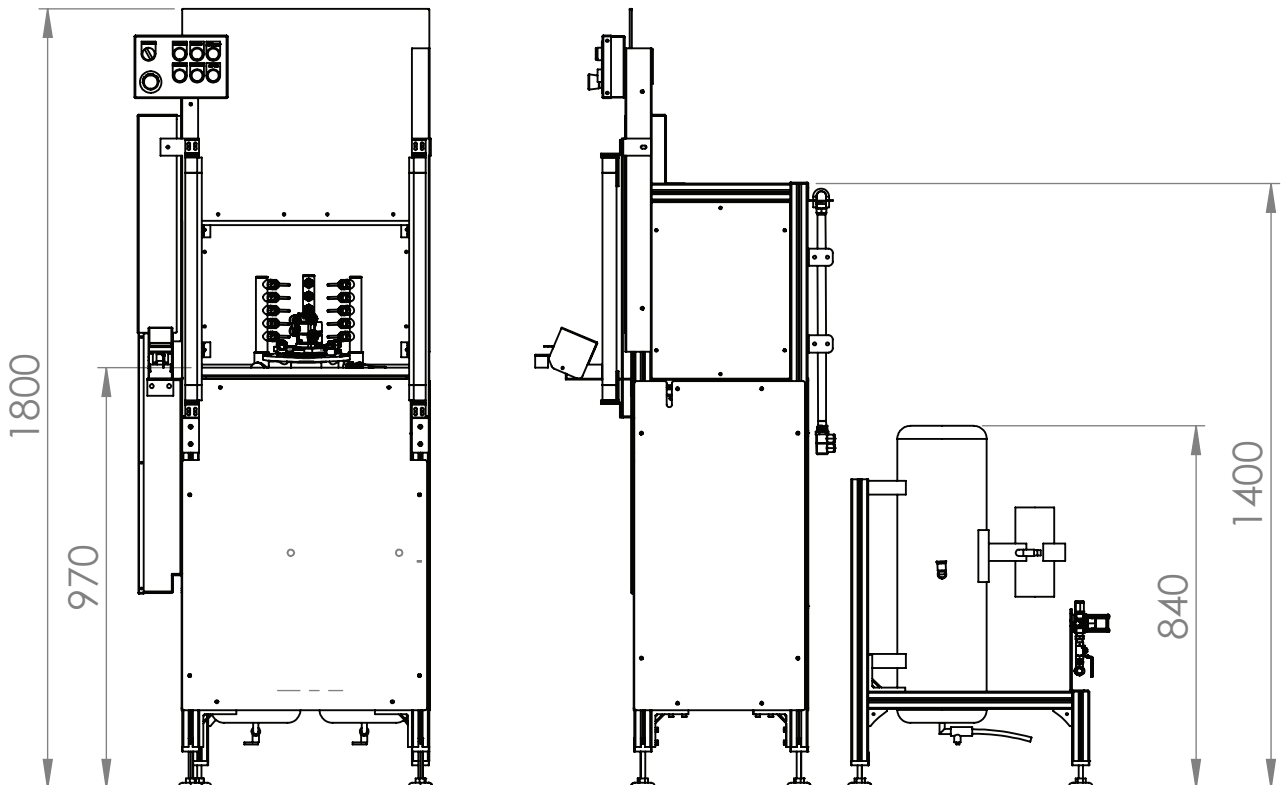
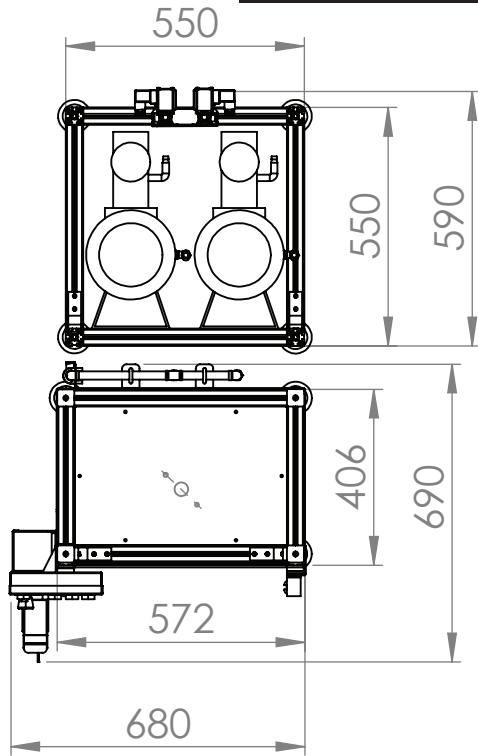

PARTS LIST

SET : AIR BLOWER1

SET : AIR TANK2

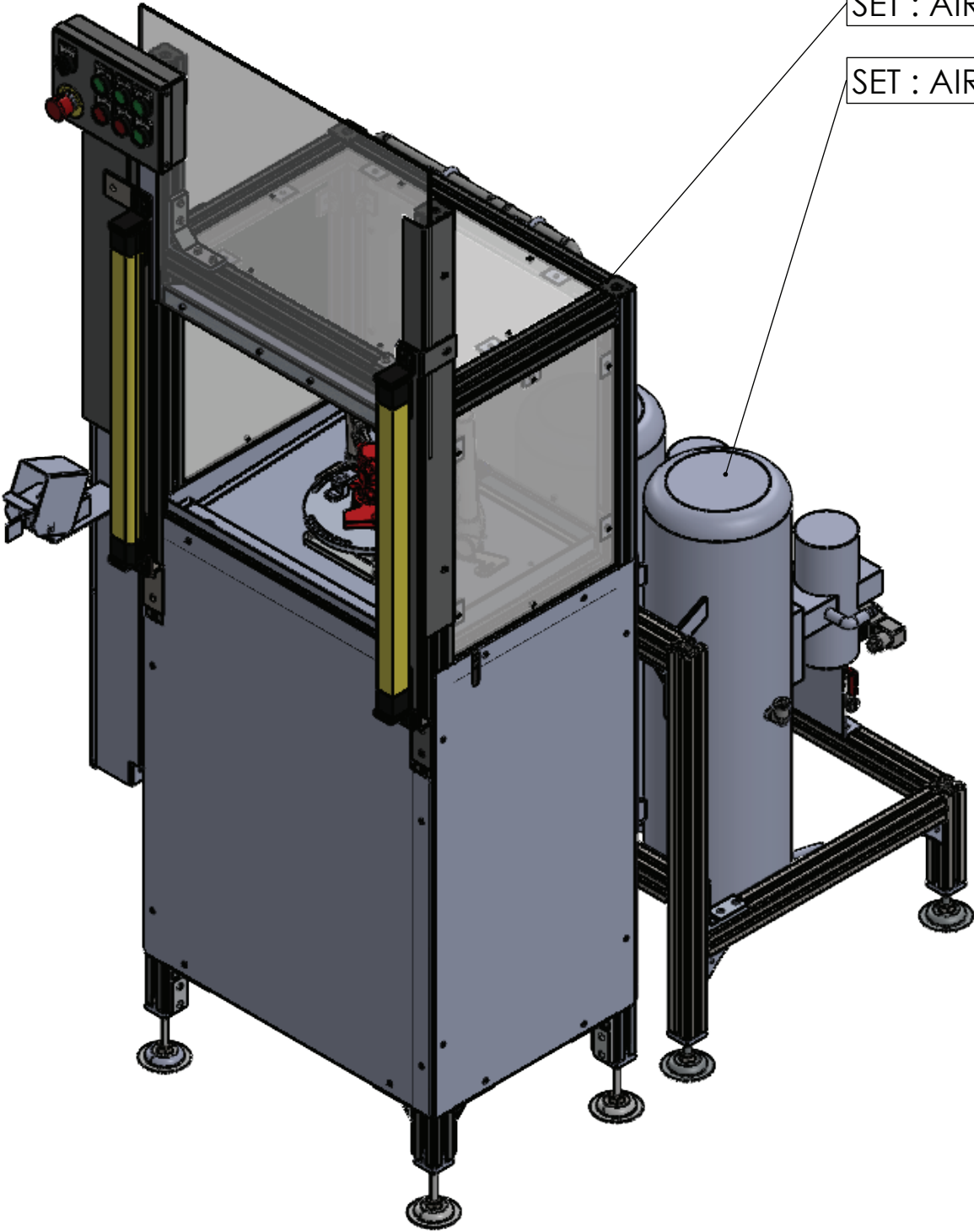

PARTS LIST

SET : AIR BLOWER 1

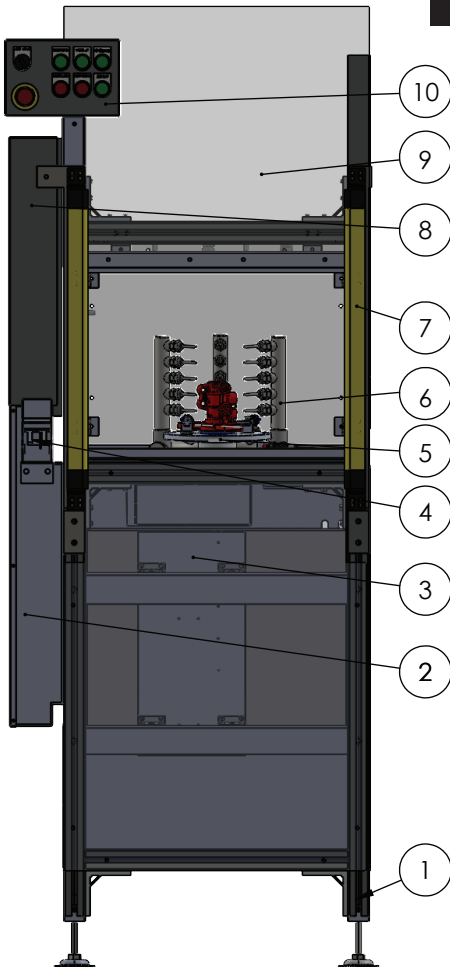

ITEM NO.	DESCRIPTION	PART NUMBER	QTY.
1	ALUMINUM FRAME	HFS8-4040	
2	AIR CYLINDER SMC	CDM2L25-450Z	1
3	SET BLOWER SLIDING	PAGE 7	
4	LIMIT SWITCH OMROM	HL-5050	1
5	SET CYLINDER	PAGE 9	
6	SET AIR PIPE 1 INCH	PAGE 9	
7	SAFETY LIGHT CURTAIN	KEYNCE=GL-R14L	2
8	COVER AIR CYLINDER	TECH BUILD	1
9	POLYCARBONATE SHEETS	5 SHEETS	
10	KEYPAD	PAGE 22	
11	AIR COMBINATION (SMC)	PAGE 23	
12	ELECTRIC CABINET	PAGE 24	
13	AIR PIPING ONE-TOUCH	KQ2VD12-04A	1
14	U BOLT FOR STEEL PIPES PLATE STAINLESS	SPNUBH-316L-M6	4
15	STAINLESS STEEL PIPES	TECH BUILD	

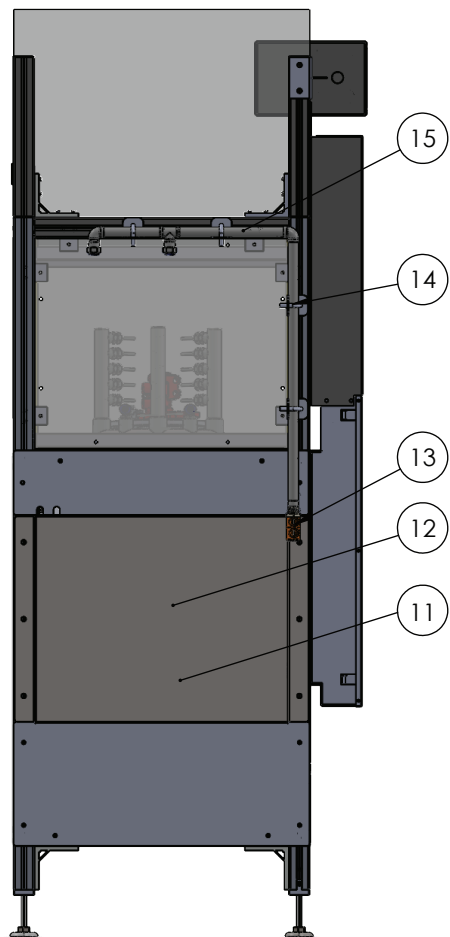

PARTS LIST

SET : AIR BLOWER 1 (SET BLOWER SLIDING)

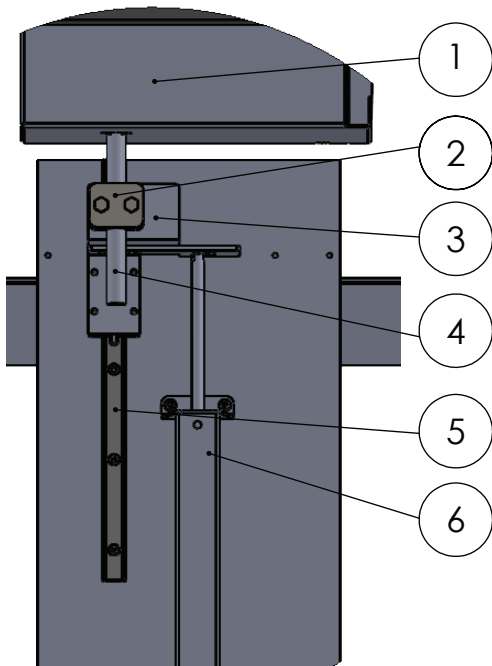

ITEM NO.	DESCRIPTION	PART NUMBER	QTY.
1	GRILLE	TECH BUILD,PAGE 7	1
2	PIPES CLAMP	SP112PP-DP-AP	1
3	STAINLESS STEEL	TECH BUILD,PAGE 8	1
4	AIR BLOW PIPE	TECH BUILD,PAGE 8	1
5	LINEAR GUIDE MISUMI	C-SXR24-280	1
6	AIR CYLINDER SMC	CDQSG16-150DC	1

GRILLE

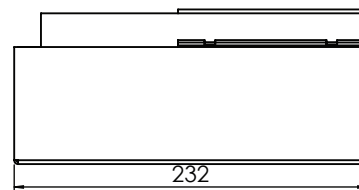
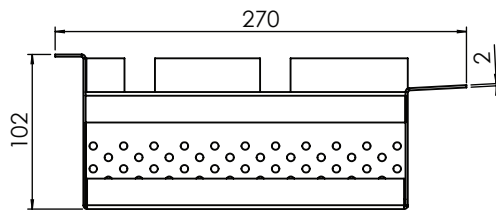
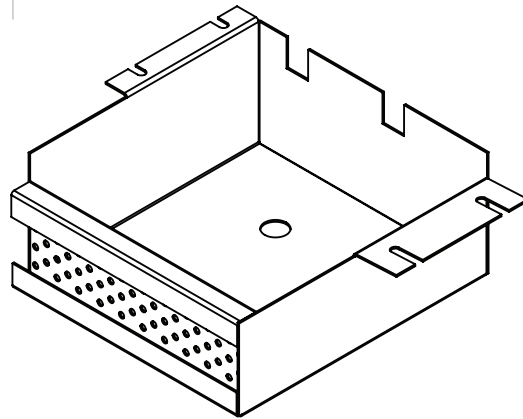
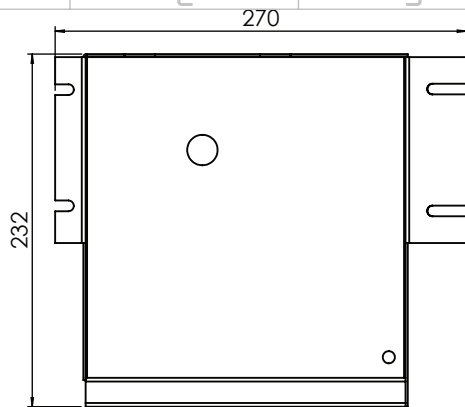

วัสดุ : SUS304 2 mm.	PRODUCT NAME : ITEM NO. 1
จำนวน : หนึ่ง	ENTERPRISE : TECHNICIANSERVICE CO.,LTD
วิธี Laser cutting 1 มม. น	UNIT : Millimetre (mm.)
SCALE :	Date : 11 / 07 / 2566
	SHEET 1 OF 1

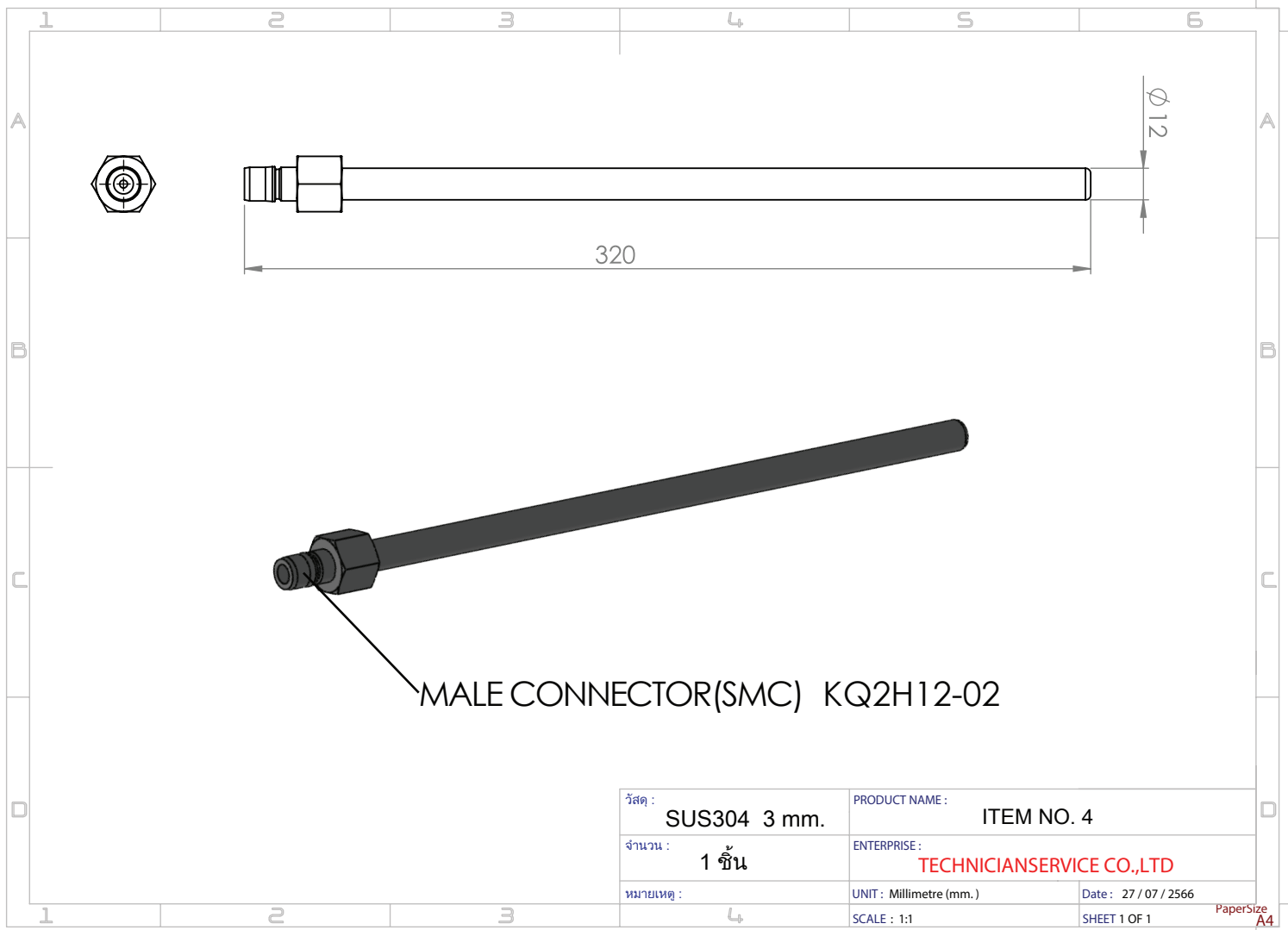
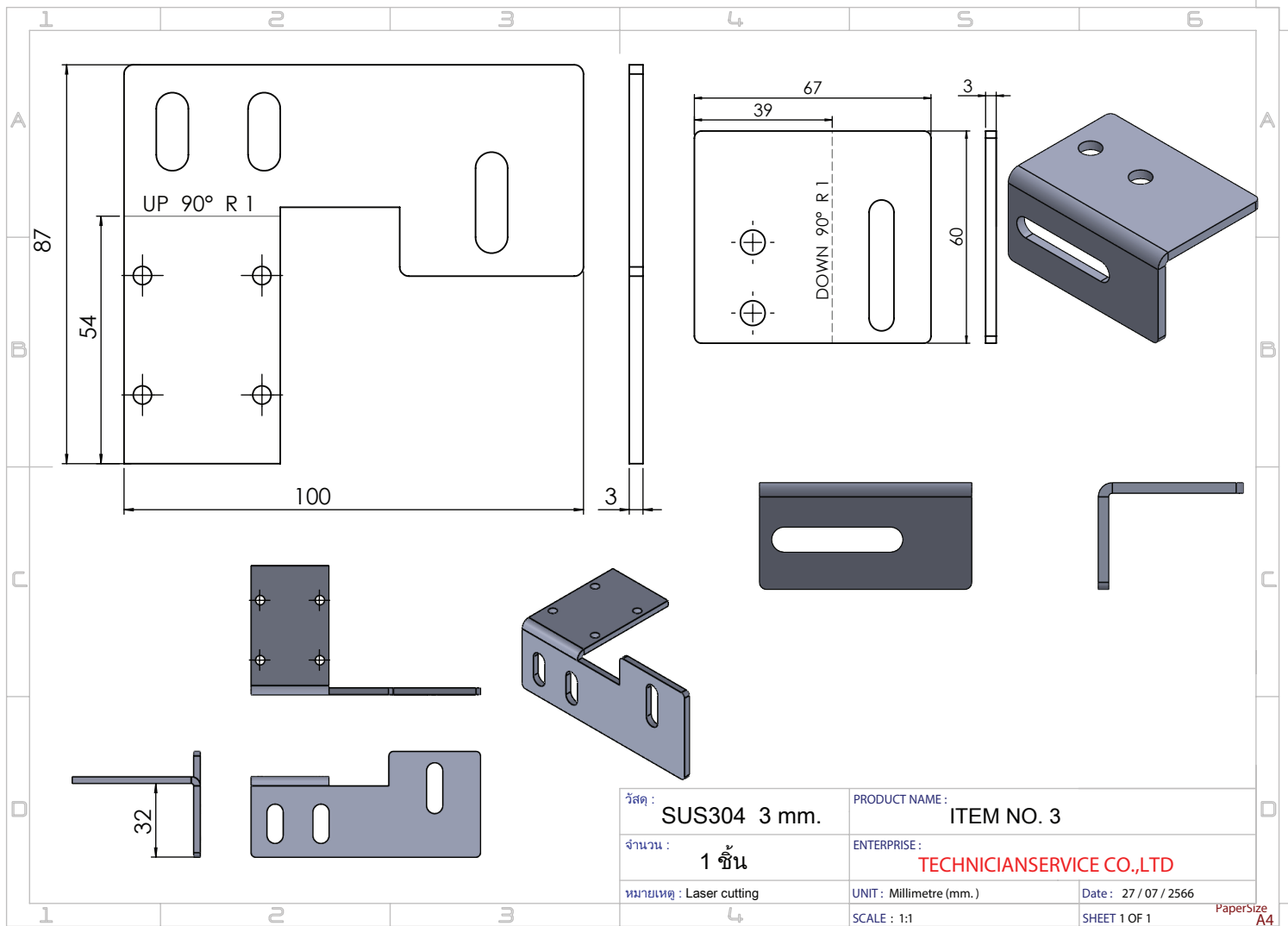

PARTS LIST

SET : AIR BLOWER 1 (SET CYLINDER)

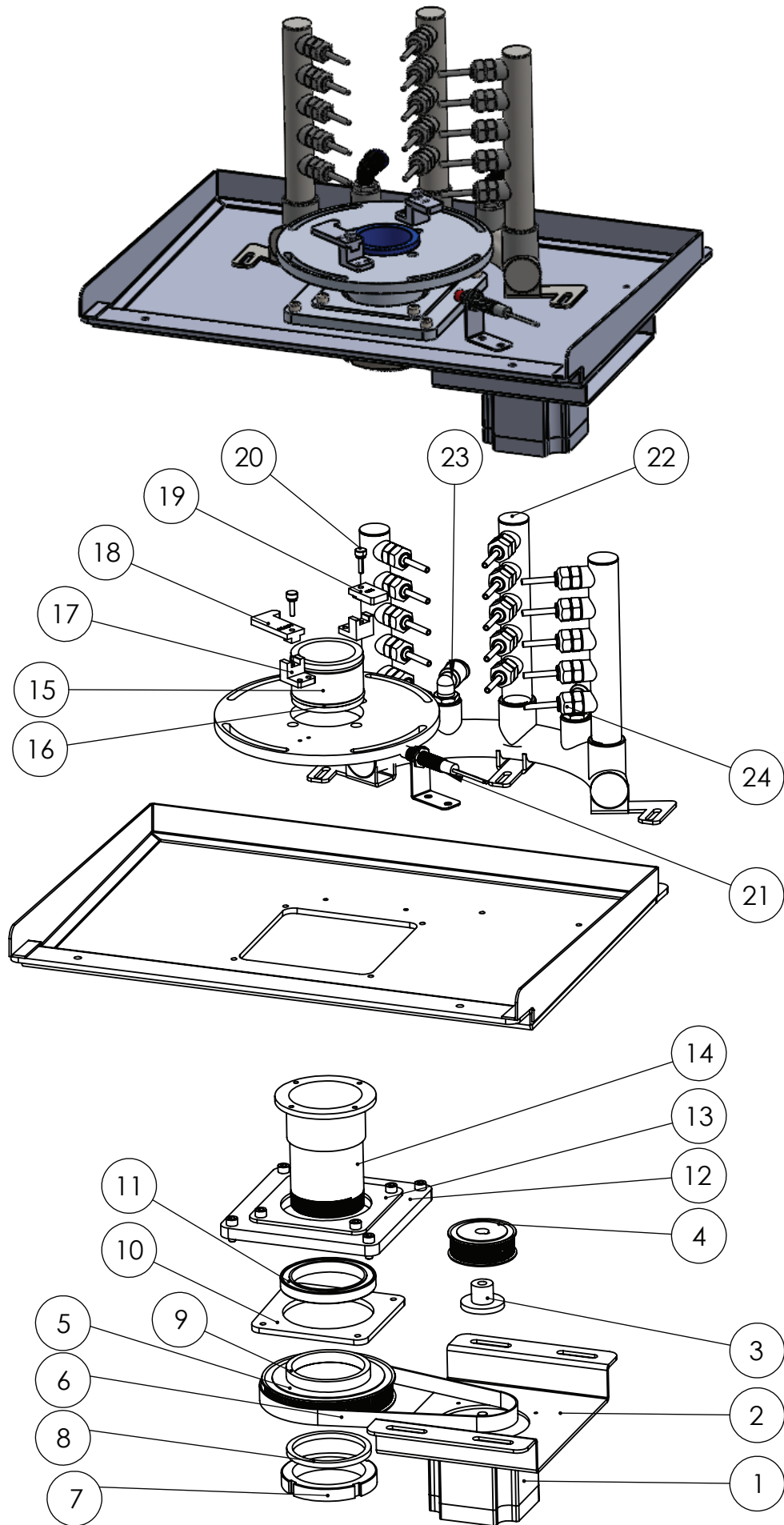

ITEM NO.	DESCRIPTION	PART NUMBER	QTY.
1	AC STANDARD MOTOR	SMK550C-GN	1
2	ORIENTAL MOTOR	TECH BUILD , PAGE 11	1
3	PLATE STEEL	TECH BUILD , PAGE 11	1
4	SHAFT COLLARS	HTPA36S5M150-A-C12	1
5	PULLEYS S5M	HTPA72S5M150-A-C12	1
6	PULLEYS S5M	HTBN590S5M-150	1
7	Timing Belts/S5M	FUJI SEIMITSU FUN13SUS	1
8	LOCK NUT M65x2	TECH BUILD , PAGE 12	1
9	COLLARS	TECH BUILD , PAGE 12	1
10	COLLARS	TECH BUILD , PAGE 12	1
11	PLATE ALUMINIUM	TECH BUILD , PAGE 13	1
12	BALL BEARING	NSK 6813DDU	1
13	PLATE ALUMINIUM	TECH BUILD , PAGE 13	1
14	PLATE ALUMINIUM	TECH BUILD , PAGE 14	1
15	CYLINDER STEEL	TECH BUILD , PAGE 14	1
16	CYLINDER MC NYLON	TECH BUILD , PAGE 15	1
17	O-RING	SIZE G65	1
18	SUPPORT FLANGE	BOSCH BUILD , PAGE 16	2
19	ADAPTER PLATE	BOSCH BUILD , PAGE 17 -20	1
20	ADAPTER PLATE	BOSCH BUILD , PAGE 17 -20	1
21	HEAD KNURLED SCREW	SPNFL-BRN-M4-15	1
22	PROXIMITY+ PLATE	SI12SM-BE4NO-N9192022 TECH BUILD , PAGE 15	1
23	BLOW PIPES	TECH BUILD , PAGE 21	1
24	ONE-TOUCH COUPLINGS	MISUMI= MSELL12-4	2
24	POINT NOZZLES	MISUMI=PNZRF1-3-30	15

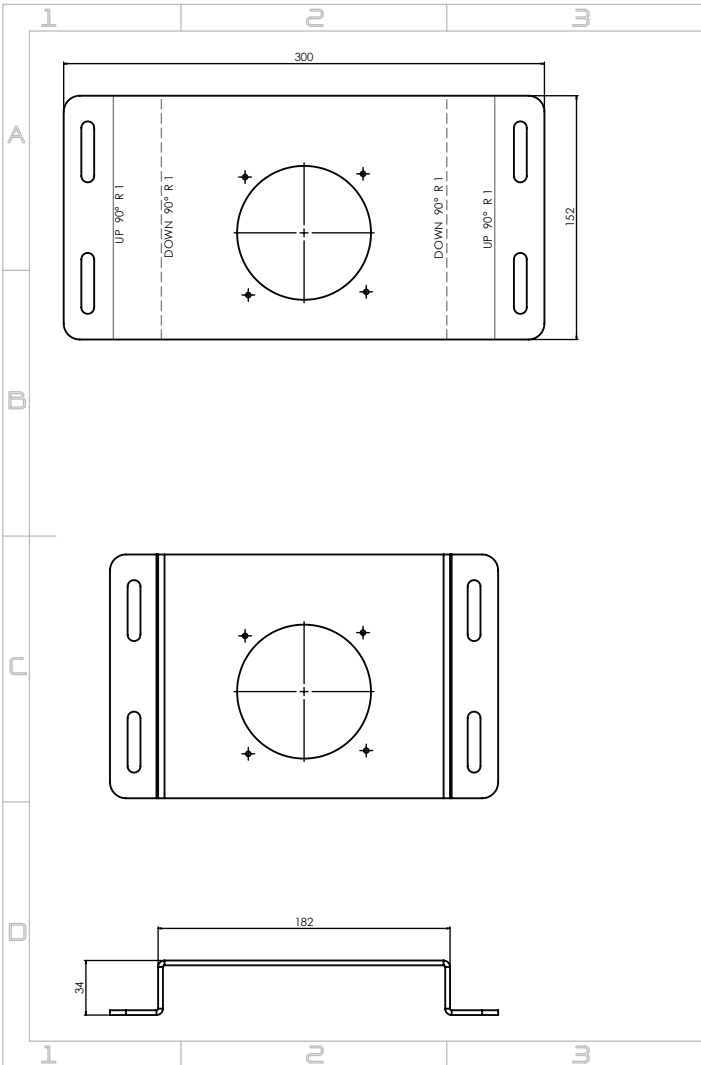

วัสดุ :	เหล็ก	PRODUCT NAME :	ITEM NO. 2
จำนวน :	1 ชิ้น	ENTERPRISE :	TECHNICIANSERVICE CO.,LTD
หมายเหตุ :	ทำขึ้นเอง	UNIT : Millimetre (mm.)	Date : 10 / 07 / 2566
		SCALE : 1:1	SHEET 1 OF 1

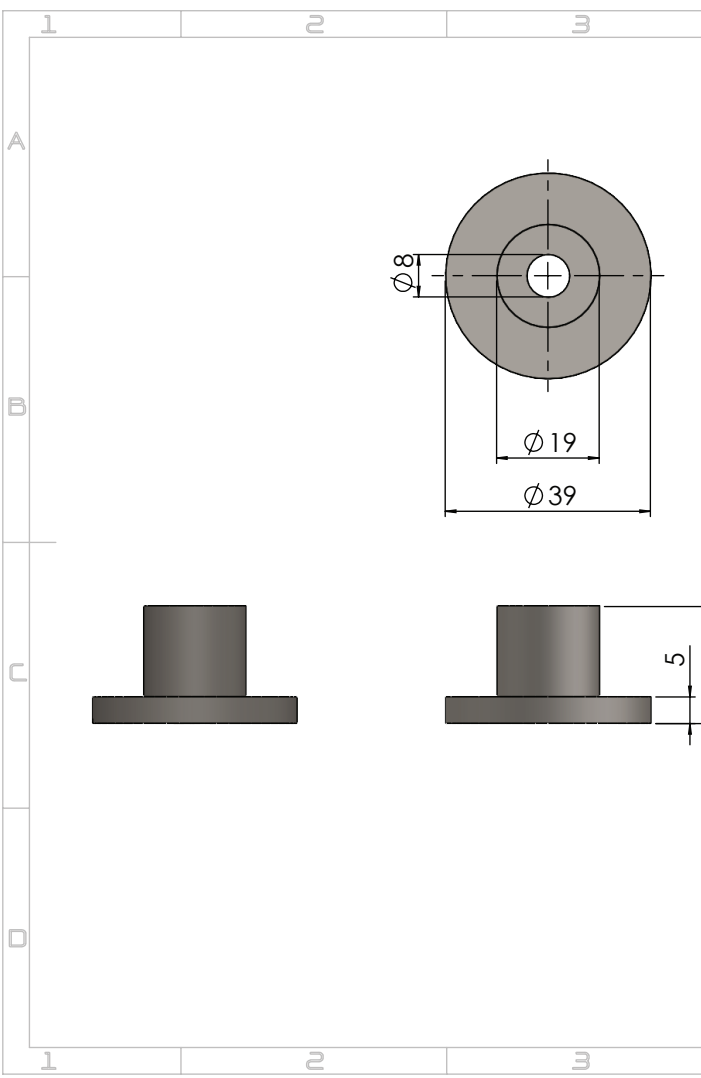
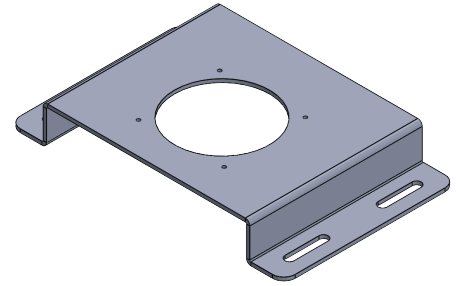

วัสดุ :	เหล็ก	PRODUCT NAME :	ITEM NO. 3
จำนวน :	1 ชิ้น	ENTERPRISE :	TECHNICIANSERVICE CO.,LTD
หมายเหตุ :		UNIT : Millimetre (mm.)	Date : 10 / 07 / 2566
		SCALE : 1:1	SHEET 1 OF 1

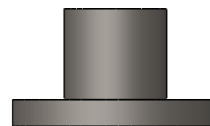
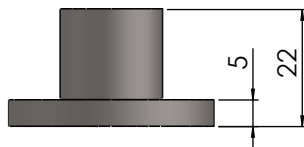
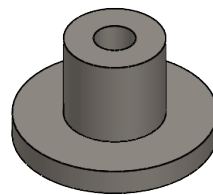

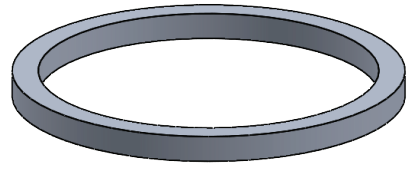
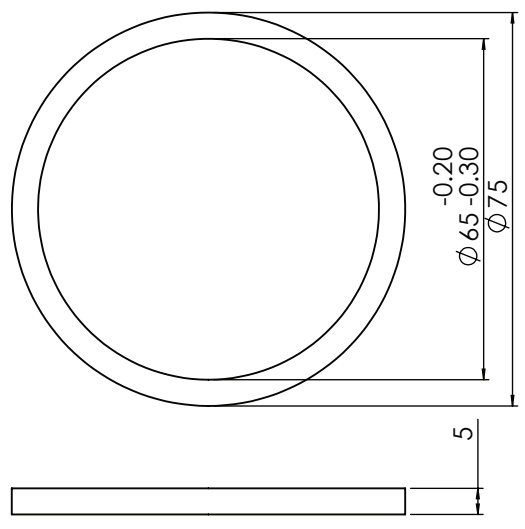

วัสดุ : เหล็กหนา 5 mm.	PRODUCT NAME : ITEM NO. 8
จำนวน : 1 ชิ้น	ENTERPRISE : TECHNICIANSERVICE CO.,LTD
หมายเหตุ : Leser Cutting	UNIT : Millimetre (mm.)
	Date : 12 / 07 / 2566
	SCALE : 1:1
	SHEET 4 OF 4

PaperSize A4

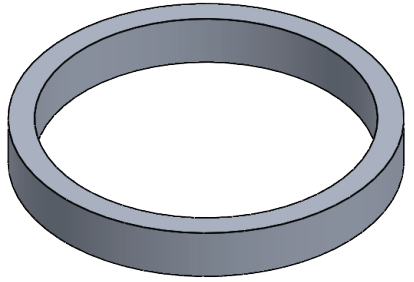
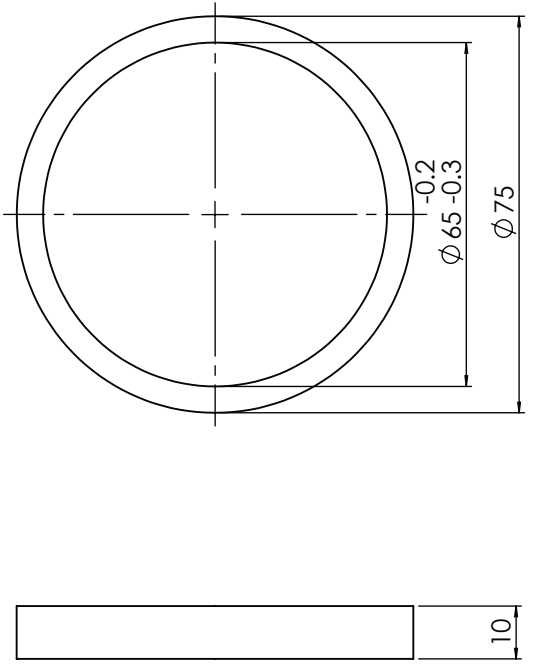

วัสดุ : เหล็กหนา 10 mm.	PRODUCT NAME : ITEM NO. 9
จำนวน : 1 ชิ้น	ENTERPRISE : TECHNICIANSERVICE CO.,LTD
หมายเหตุ : Leser Cutting	UNIT : Millimetre (mm.)
	Date : 12 / 07 / 2566
	SCALE : 1:1
	SHEET 1 OF 1

PaperSize A4

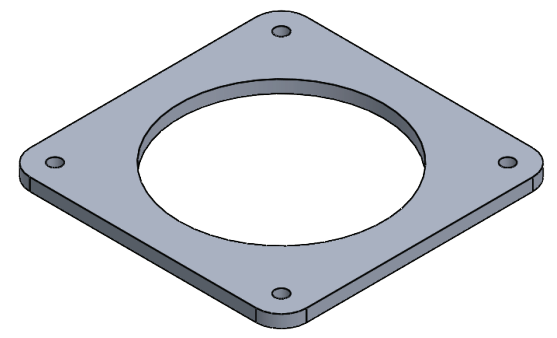
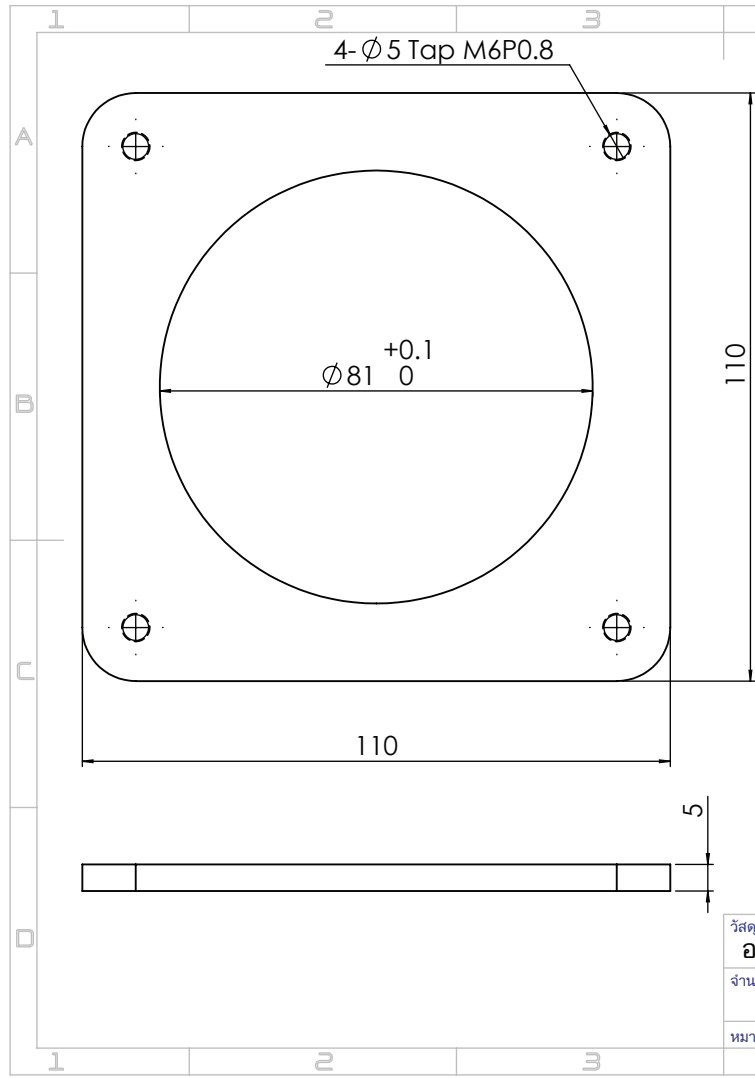

วัสดุ : อลูมิเนียมหนา 5 mm.	PRODUCT NAME : ITEM NO. 10
จำนวน : 1 ชิ้น	ENTERPRISE : TECHNICIANSERVICE CO.,LTD
หมายเหตุ : Leser Cutting	UNIT : Millimetre (mm.) Date : 12 / 07 / 2566 SCALE : 1:1 SHEET 3 OF 4

PaperSize A4

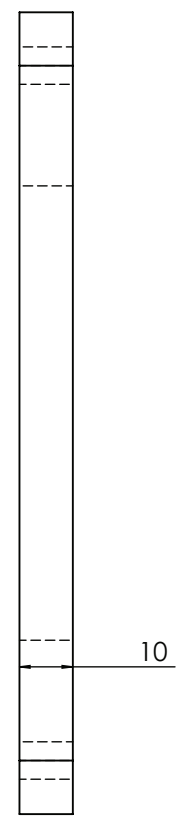
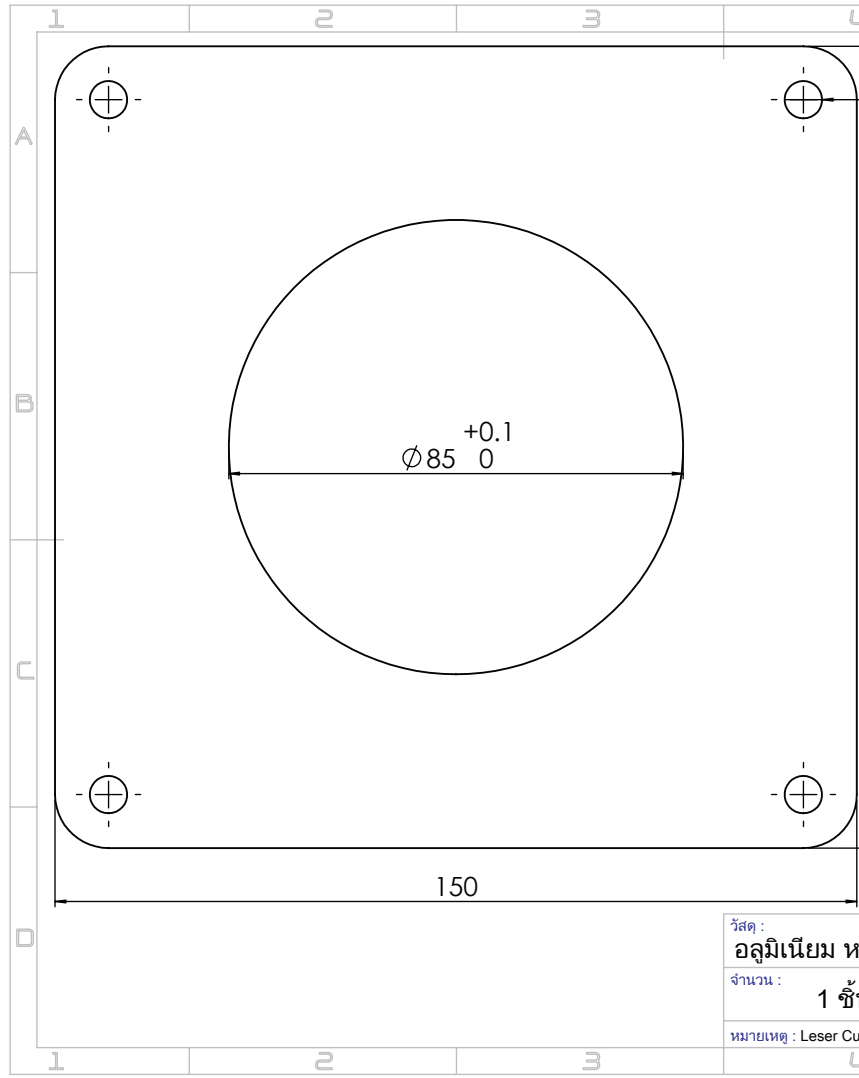

วัสดุ : อลูมิเนียมหนา 10 mm.	PRODUCT NAME : ITEM NO. 12
จำนวน : 1 ชิ้น	ENTERPRISE : TECHNICIANSERVICE CO.,LTD
หมายเหตุ : Leser Cutting	UNIT : Millimetre (mm.) Date : 12 / 07 / 2566 SCALE : 1:1 SHEET 2 OF 4

PaperSize A4

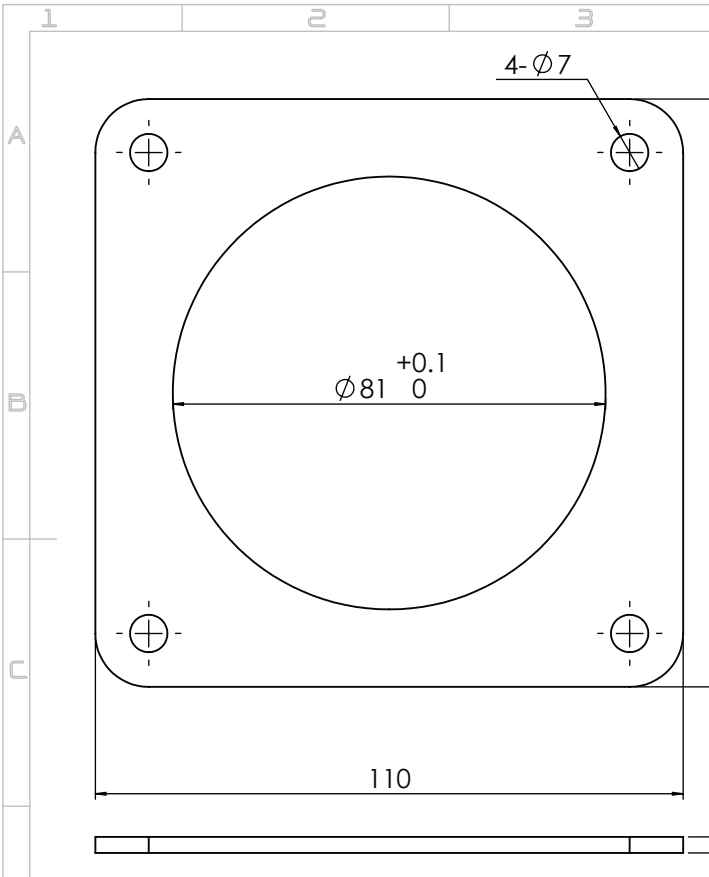

วัสดุ : อลูมิเนียมหนา 3 mm.	PRODUCT NAME : ITEM NO. 13
จำนวน : 1 ชิ้น	ENTERPRISE : TECHNICIANSERVICE CO.,LTD
หมายเหตุ : Leser Cutting	UNIT : Millimetre (mm.) SCALE : 1:1
	Date : 12 / 07 / 2566 SHEET 1 OF 4

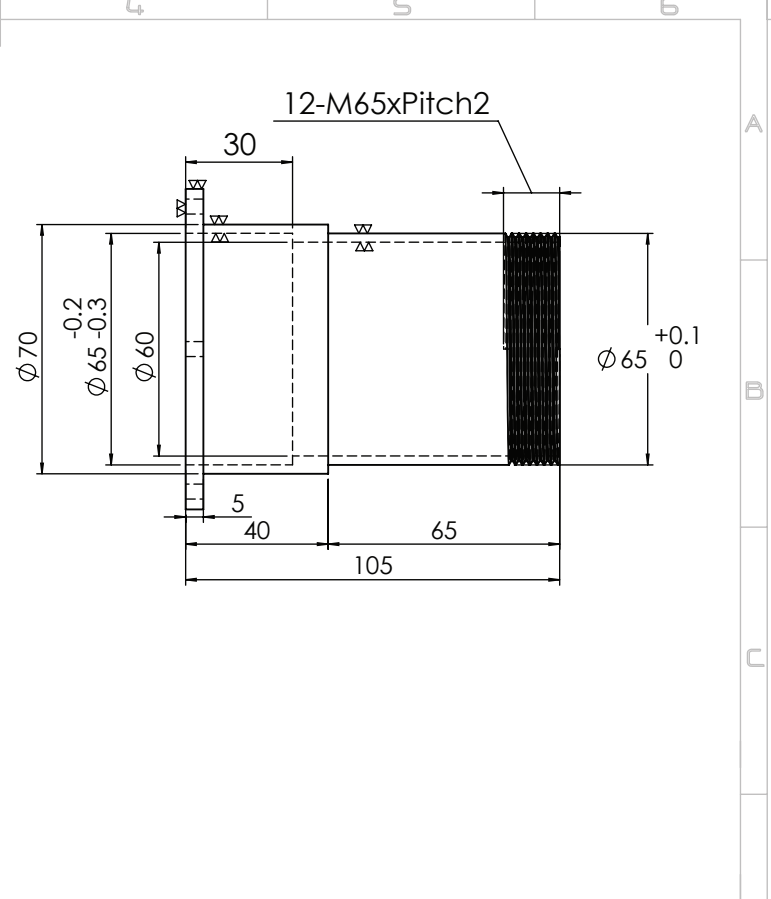
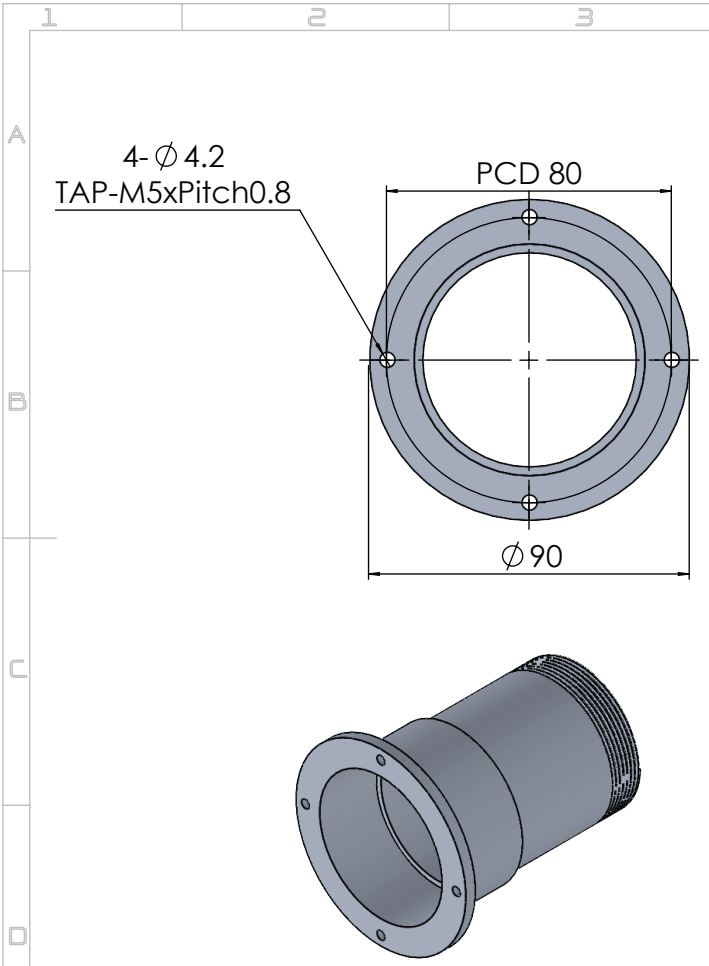

วัสดุ : เหล็ก	PRODUCT NAME : ITEM NO. 14
จำนวน : 1 ชิ้น	ENTERPRISE : TECHNICIANSERVICE CO.,LTD
หมายเหตุ : Turning Process	UNIT : Millimetre (mm.) SCALE :
	Date : 14 / 07 / 2566 SHEET 1 OF 1

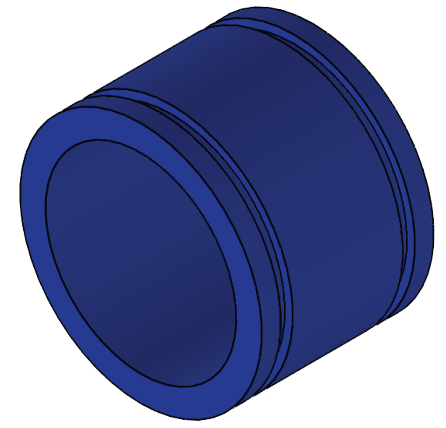
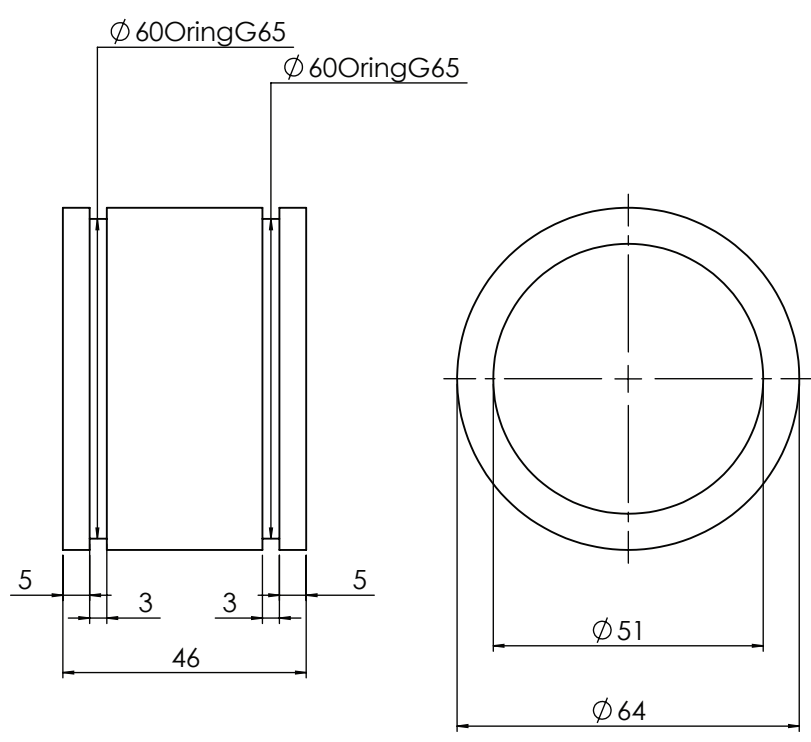

วัสดุ : McNylon	PRODUCT NAME : ITEM NO. 15
จำนวน : 1 ชิ้น	ENTERPRISE : TECHNICIANSERVICE CO.,LTD
หมายเหตุ : ทำขึ้นเอง	UNIT : Millimetre (mm.) Date : 10 / 07 / 2566
	SCALE : 1:1 SHEET 1 OF 1

PaperSize A4

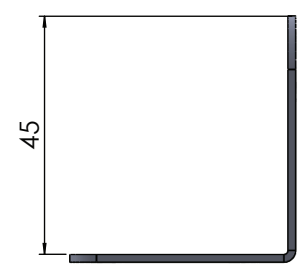
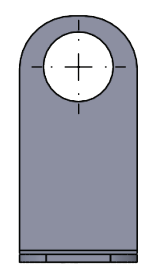
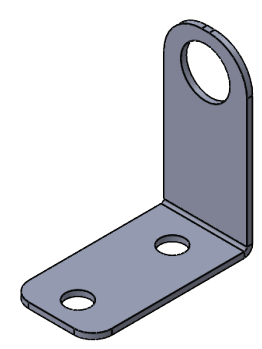
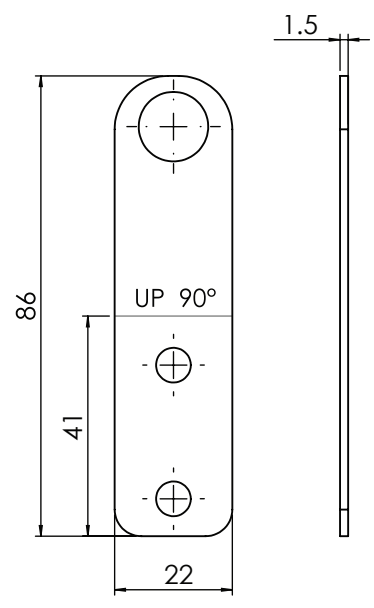

วัสดุ : สแตนเลส หนา 1.5 mm.	PRODUCT NAME : ITEM NO. 21
จำนวน : 1 ชิ้น	ENTERPRISE : TECHNICIANSERVICE CO.,LTD
หมายเหตุ :	UNIT : Millimetre (mm.) Date : 10 / 07 / 2566
	SCALE : 1:1 SHEET 1 OF 1

PaperSize A4

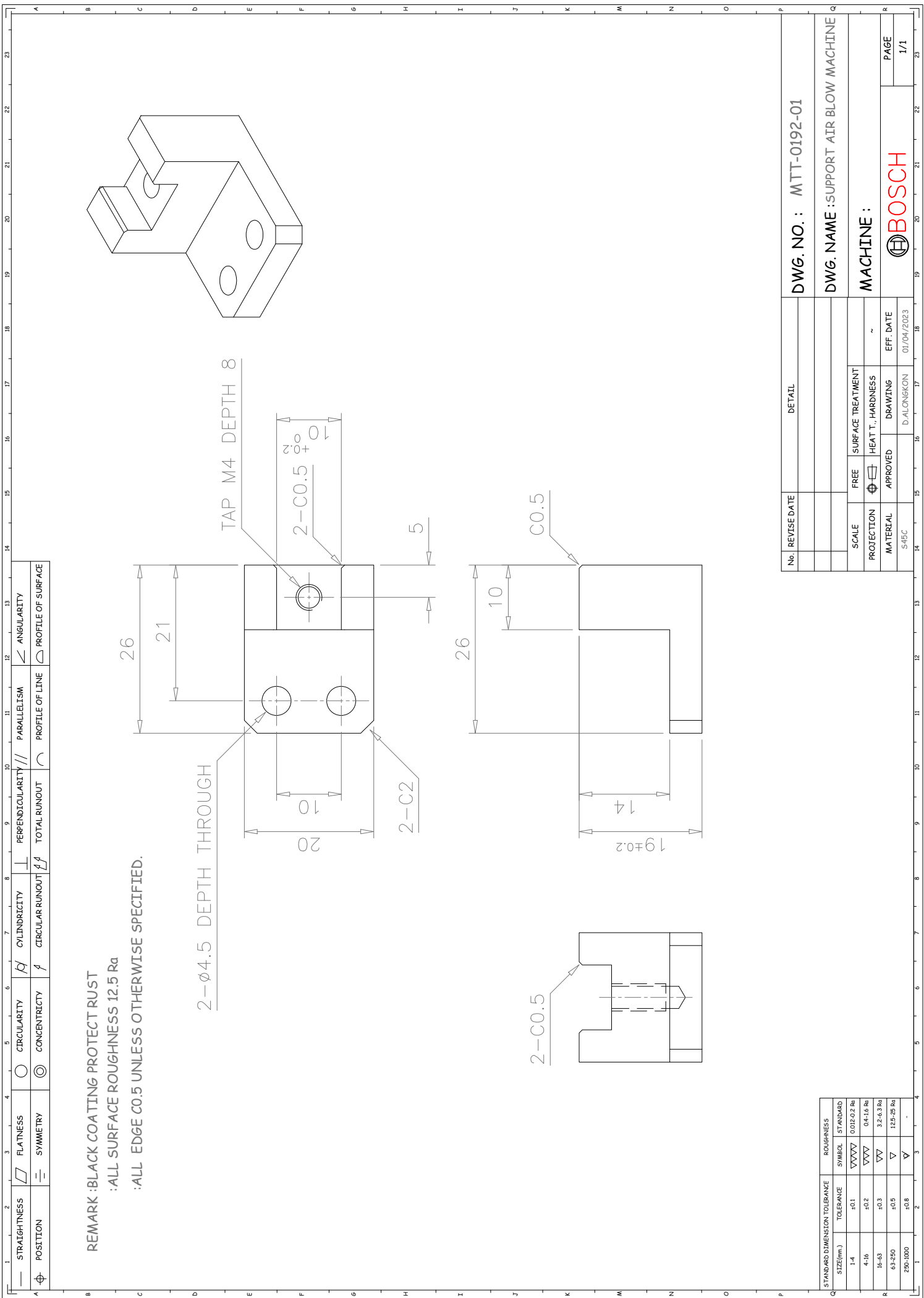

REMARK : BLACK COATING PROTECT RUST
 : ALL SURFACE ROUGHNESS 12.5 Ra
 : ALL EDGE C0.5 UNLESS OTHERWISE SPECIFIED.

1	2	3	4	5	6	7	8	9	10	11	12	13	14	15	16	17	18	19	20	21	22	23
STRAIGHTNESS		FLATNESS		CIRCULARITY	CYLINDRICITY	PERPENDICULARITY	PARALLELISM	ANGULARITY	TOTAL RUNOUT		PROFILE OF LINE		PROFILE OF SURFACE									
POSITION		SYMMETRY		CONCENTRICITY	CIRCULAR RUNOUT																	

STANDARD DIMENSION TOLERANCE SIZE(mm)	TOLERANCE		ROUGHNESS	
	MIN	MAX	SYMBOL	STANDARD
1-4	±0.1		VVVV	0.012-0.2 Rn
4-16	±0.2		VVV	0.4-1.6 Rn
16-63	±0.3		VV	3.2-6.3 Rn
63-250	±0.5		V	12.5-25 Rn
250-1000	±0.8		∇	-

No.	REVISE DATE	DETAIL	
DWG. NO. : MTT-0192-01			
DWG. NAME : SUPPORT AIR BLOW MACHINE			
MACHINE :			
SCALE		FREE	SURFACE TREATMENT
PROJECTION		APPROVED	HEAT T., HARDNESS
MATERIAL		S45C	DRAWING
			EFF. DATE
			01/04/2023
			D. ALONGKON
			PAGE
			1/1



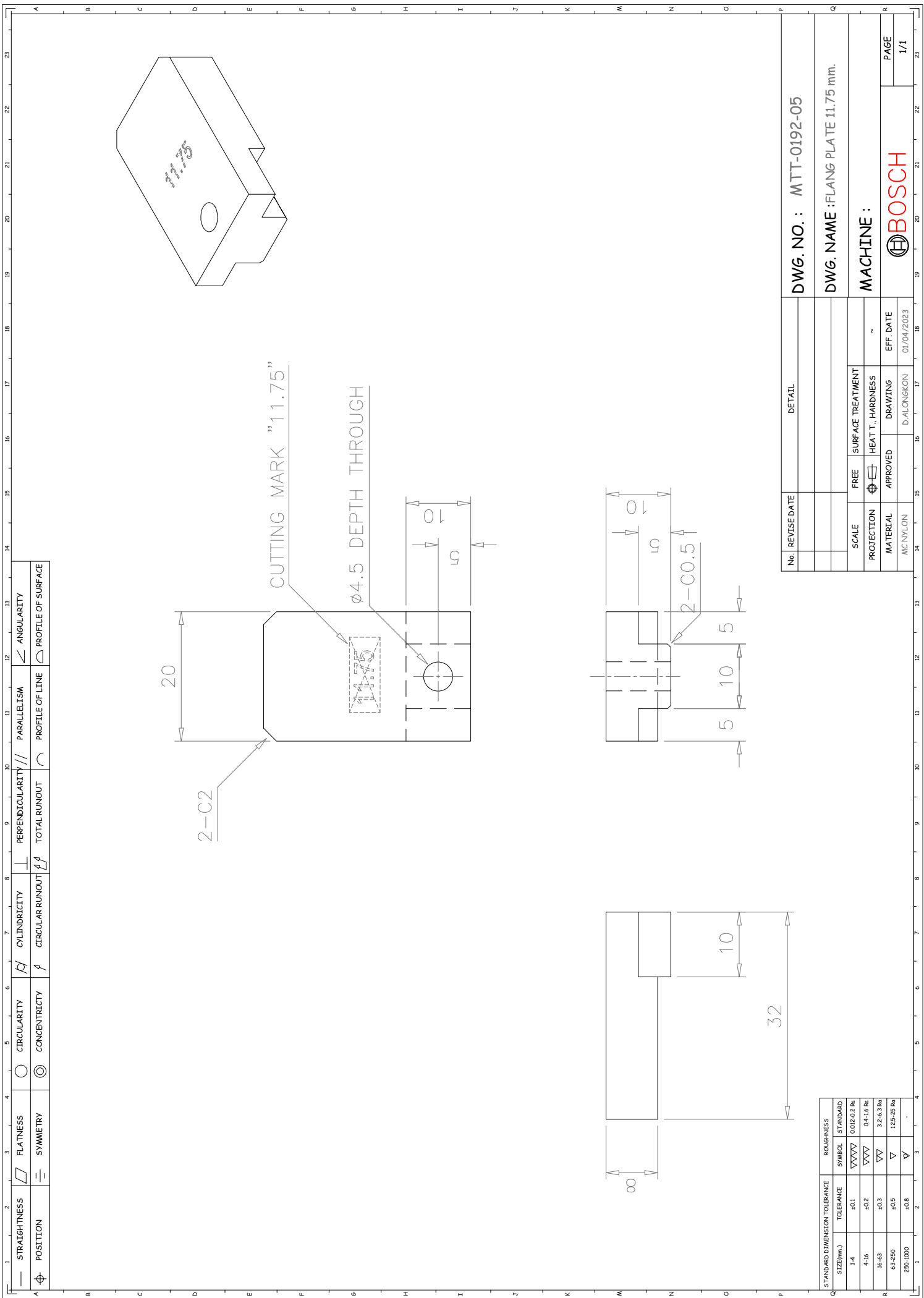

1	2	3	4	5	6	7	8	9	10	11	12	13	14	15	16	17	18	19	20	21	22	23	
—	STRAIGHTNESS	∥	FLATNESS	○	CIRCULARITY	⊂	CYLINDRICITY	⊥	PERPENDICULARITY	∥	PARALLELISM	∠	ANGULARITY	⊕	TOTAL RUNOUT	⌒	PROFILE OF LINE	⊖	PROFILE OF SURFACE				
⊕	POSITION	≡	SYMMETRY	◎	CONCENTRICITY	∠	CIRCULAR RUNOUT	∠		∠													

No.		REVISE DATE		DETAIL	
SCALE	FREE	SURFACE TREATMENT			
PROJECTION	APPROVED	HEAT T., HARDNESS			
MATERIAL	DRAWING	EFF. DATE			
MC/NYLON	D. ALONGBKON	01/04/2023			
DWG. NO. : MTT-0192-05				PAGE	
DWG. NAME : FLANG PLATE 11.75 mm.				1/1	
MACHINE :				PAGE	
BOSCH				1/1	

STANDARD DIMENSION TOLERANCE SIZE(mm)	ROUGHNESS	
	TOLERANCE	SYMBOL
1-4	±0.1	VVVV 0.012-0.2 Rn
4-16	±0.2	VVV 0.4-1.6 Rn
16-63	±0.3	VV 3.2-6.3 Rn
63-250	±0.5	V 12.5-25 Rn
250-1000	±0.8	∇

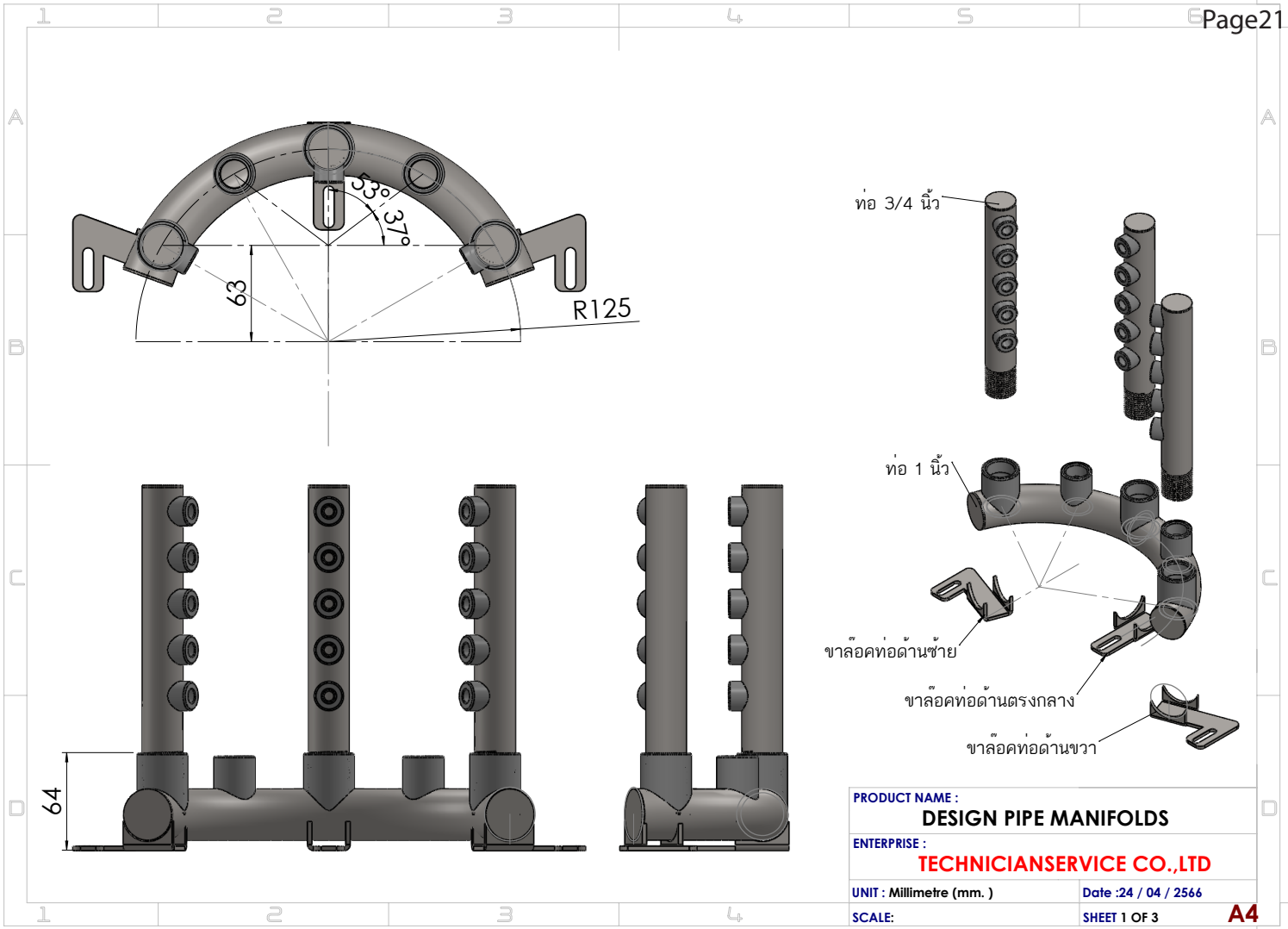

A4

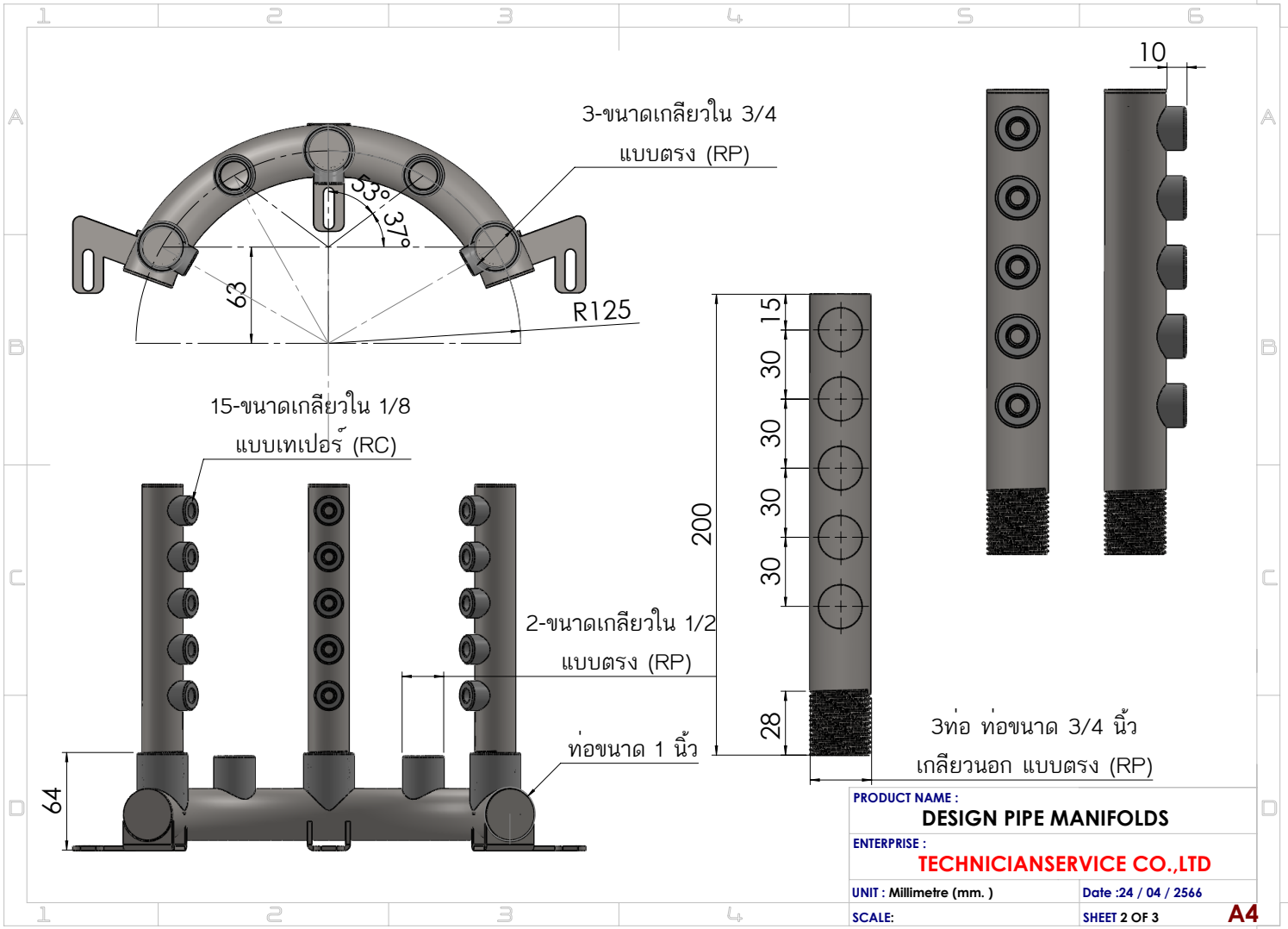

A4

PARTS LIST

SET : AIR BLOWER 1 (KEYPAD)

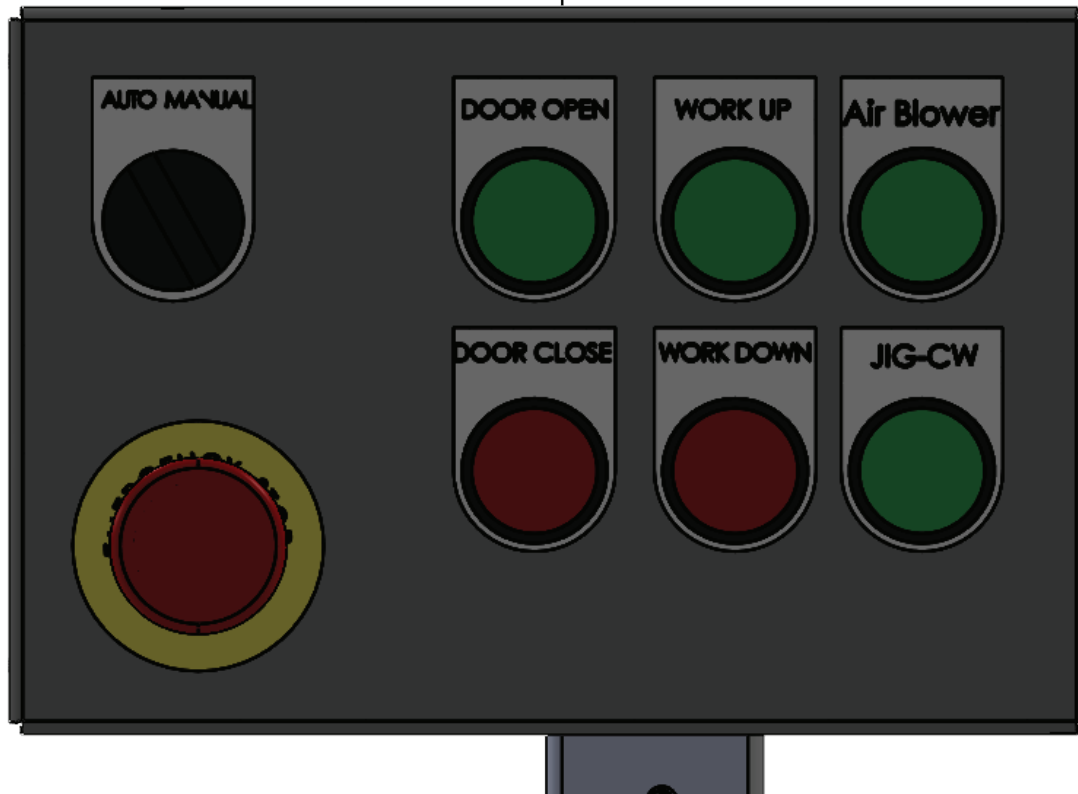

SWITCH. AUTO AND MANUAL.

AUTO = THE KEYPAD CANNOT BE USED.

MANUAL = CAN BE USED KEYPAD DOOR OPEN, DOOR CLOSE,
= WORK UP, WORK DOWN, AIR BLOWER, JIG-CW

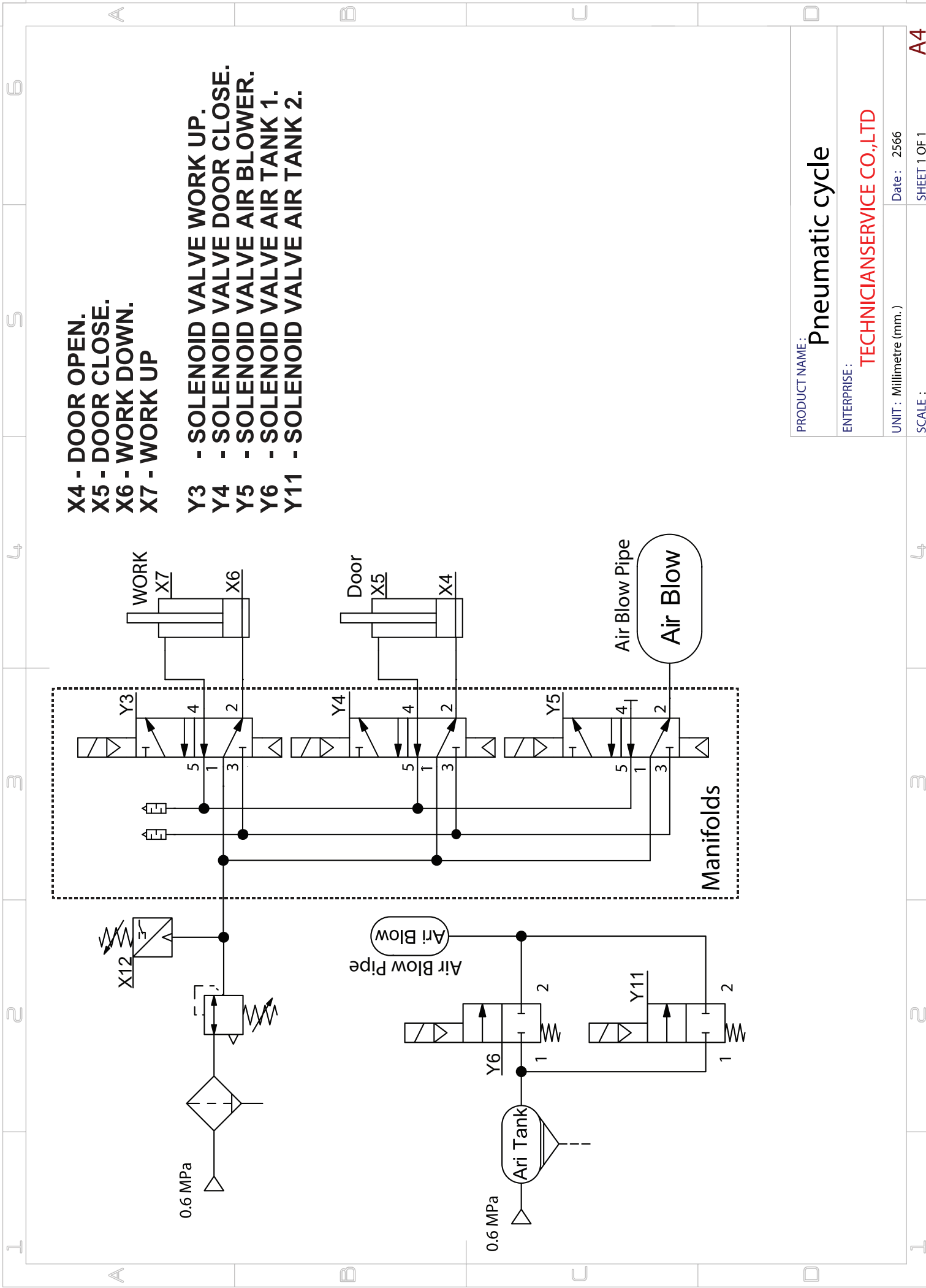

X4 - DOOR OPEN.
X5 - DOOR CLOSE.
X6 - WORK DOWN.
X7 - WORK UP

Y3 - SOLENOID VALVE WORK UP.
Y4 - SOLENOID VALVE DOOR CLOSE.
Y5 - SOLENOID VALVE AIR BLOWER.
Y6 - SOLENOID VALVE AIR TANK 1.
Y11 - SOLENOID VALVE AIR TANK 2.

PRODUCT NAME: **Pneumatic cycle**
 ENTERPRISE: **TECHNICIAN SERVICE CO.,LTD**
 UNIT: Millimetre (mm.) Date: 2566
 SCALE: SHEET 1 OF 1

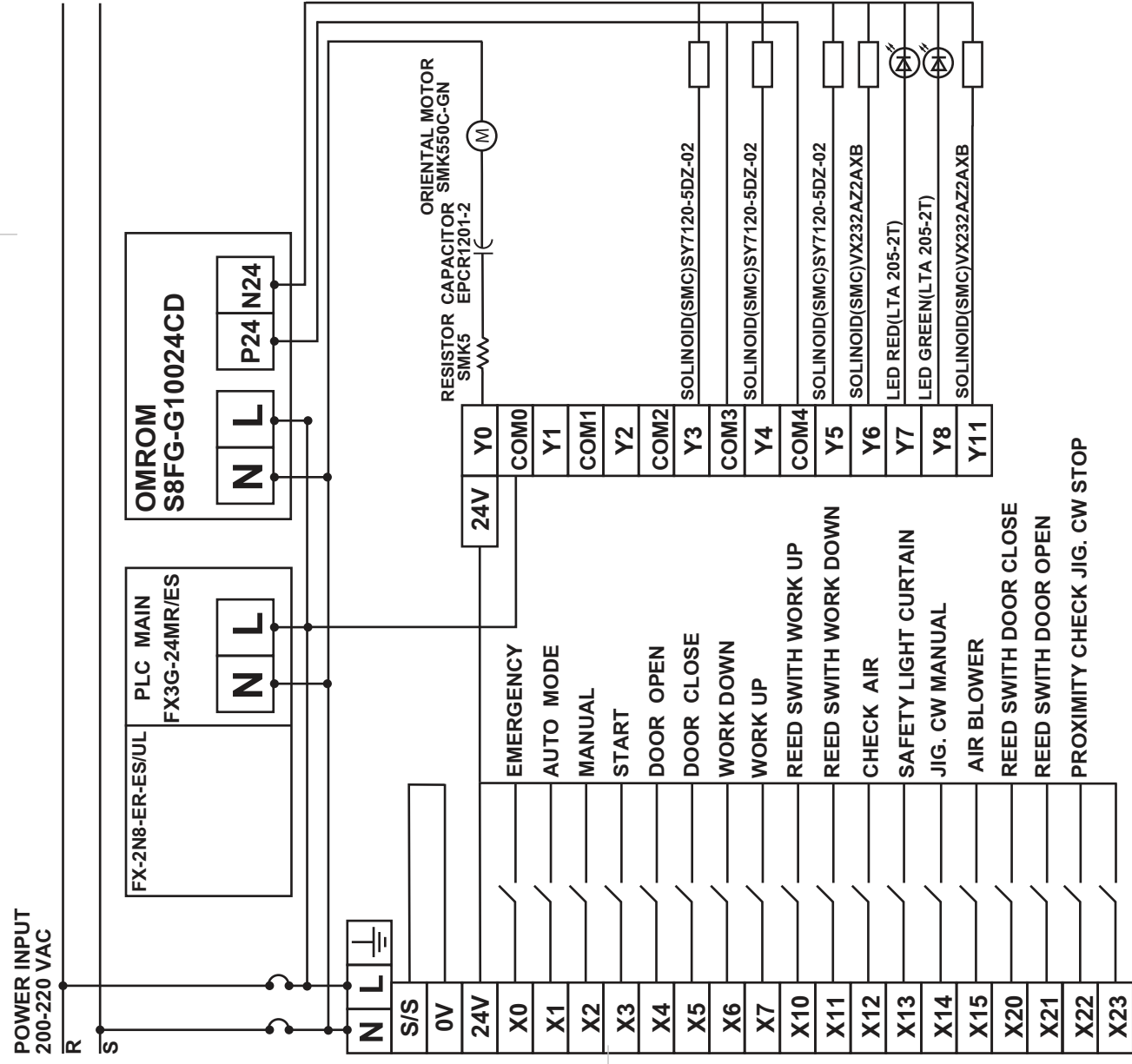

- X0 - EMERGENCY.
- X1 - AUTO MODE.
- X2 - MANUAL.
- X3 - START.
- X4 - DOOR OPEN.
- X5 - DOOR CLOSE.
- X6 - WORK DOWN.
- X7 - WORK UP
- X10 - REED SWITCH WITH WORK UP
- X11 - REED SWITCH WITH WORK DOWN.
- X12 - CHECK AIR.
- X13 - SAFETY LIGHT CURTAIN.
- X14 - JIG. CW MUNUAL.
- X15 - AIR BLOWER.
- X20 - REED SWITCH DOWN CLOSE.
- X21 - REED SWITCH DOWN OPEN.
- X22 - PROXIMITY CHECK JIG. CW STOP.

- Y0 - JIG. CW MOTOR.
- Y3 - SOLENOID VALVE WORK UP.
- Y4 - SOLENOID VALVE DOOR CLOSE.
- Y5 - SOLENOID VALVE AIR BLOWER.
- Y6 - SOLENOID VALVE AIR TANK 1.
- Y7 - LED RED.
- Y8 - LED GREEN.
- Y11 - SOLENOID VALVE AIR TANK 2.

PRODUCT NAME:
Programmable Logic Controller

ENTERPRISE:
TECHNICIANSERVICE CO.,LTD

UNIT : Millimetre (mm.) Date : 2566

SCALE : SHEET 1 OF 1

PARTS LIST

SET : AIR TANK 2

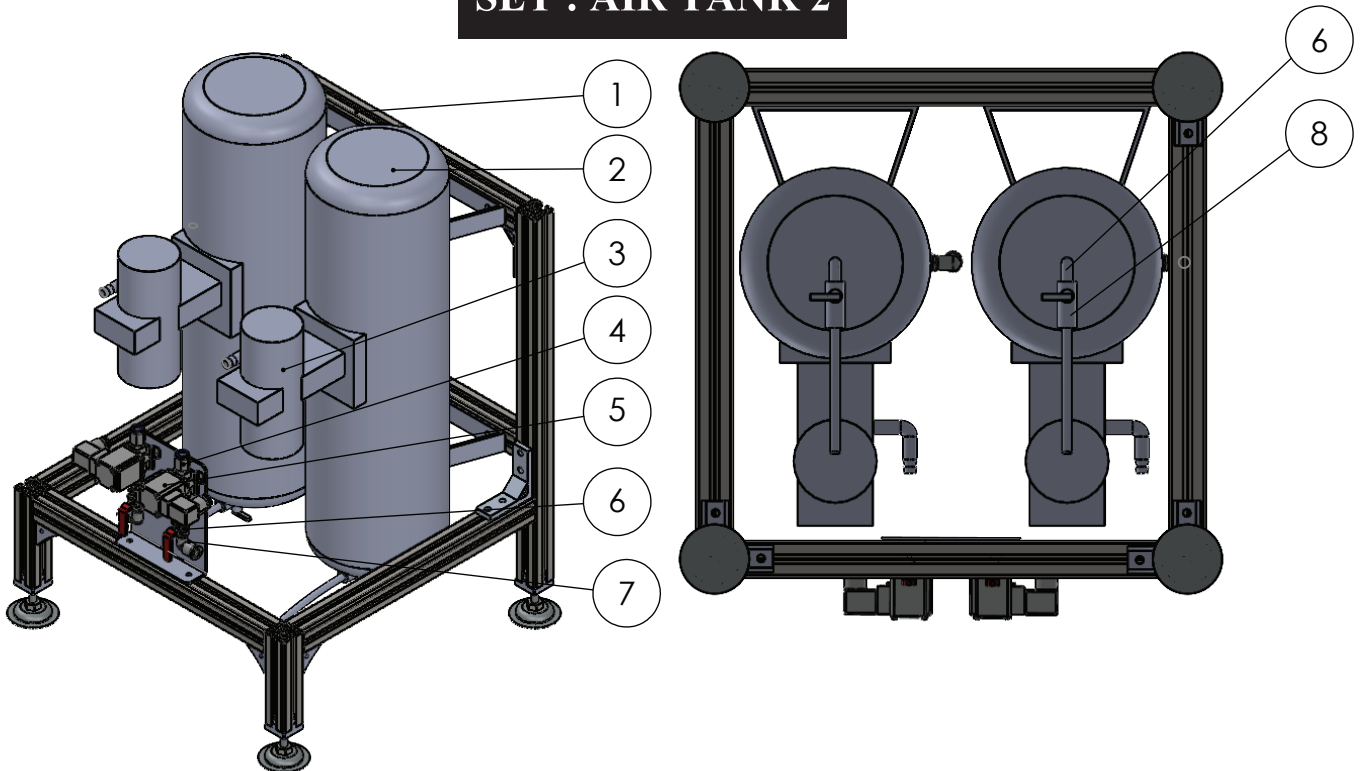

ITEM NO.	DESCRIPTION	PART NUMBER	QTY.
1	ALUMINUM FRAME	HFS8-4040	1
2	AIR TANK(SMC)	VBAT20A1-V	2
3	BOOSTER(SMC)	VBA20A-03GS	2
4	MALE CONNECTOR(SMC)	KQ2H12-02	2
5	CONTROL VALVE(SMC)	VX232AZ2AXB	2
6	BALL VALVES (MISUMI)	BRTKA8A	4
6	FITTINGS 90 DEG.(MISUMI)	SJSML8A	4
7	MALE ELBOW (SMC)	KQ2L12-02	2
8	MALE ELBOW (SMC)	KQ2H06-02	2